



Physical Ability Test (PAT) Protocol

The Physical Ability Test (PAT) will be conducted as the initial step of scheduled hiring event. All candidates are required to report to the Statesboro Bulloch Law Enforcement Training Center (37 Holland Industrial Blvd, Statesboro, GA 30461) at the scheduled time on the event day. Candidates are required to report in appropriate physical training attire. The orientation for the P.A.T. will be conducted by a staff member.

The orientation will consist of the following:

- an explanation of the course;
- an explanation of the purpose of the course;
- an explanation of the success criteria for the course, and;
- a demonstration by an Academy staff member or designee of the course.

Candidates will be allowed to ask for clarification of any issue concerning the course prior to beginning. All candidates will be required to participate in the PAT. Each candidate will be allowed two attempts to successfully complete the PAT course.

Any candidate not able to participate will be dismissed from the hiring event and be removed from the current hiring process. Those removed will be allowed to re-apply during a future hiring process.

Staff Protocol

SPD Training and/or Professional Standards staff members will oversee the conduct of the PAT. SPD staff members and their designee assigned as Course guides/spotters are NOT to assist any BLE student with the execution of the obstacle, but to provide safety assistance to mitigate the possibility of injury.



The Course

The standard for successful completion of the PAT will be for the candidate, unassisted during the event, to complete the course in two minutes and six seconds (2:06).

A time penalty (two [2] seconds added) for failure to negotiate the low crawl or the ditch jump will be imposed and added to the individual's cumulative score. Failure to negotiate any obstacle and/or to stop continuous motion will NOT constitute a "failure".

Candidates will be allowed three (3) attempts to successfully negotiate obstacles (e.g., stairs, fence, wall/window). At each failed attempt, the instructor will tell the student to back-up to a designated point in attempt to gain momentum to negotiate the obstacle. Following a third failed attempt at a given obstacle, the student will be instructed to walk around the obstacle and finish the course in order for the individual's time to be recorded for purposes of the comparison of performance (time) to ability (non-negotiation of obstacle[s]).

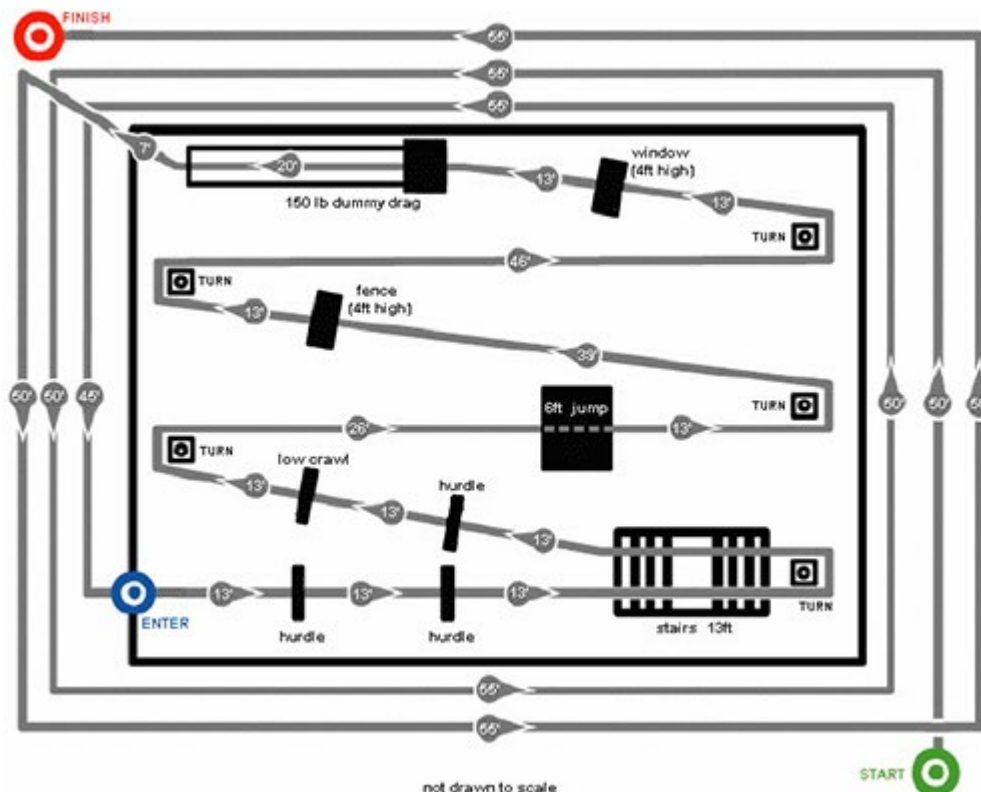



Course Description

The course measures a total of 870 feet (290 yards/ 265.2 meters). The course consists of a series of nine interspersed individual tasks, arranged in a continuous format that are viewed as being essential (physical) job-tasks for law enforcement training:

- running;
- jumping (low hurdle);
- climbing stairs;
- low crawling;
- jumping (broad-type);
- climbing a fence (chain-link/four feet); climbing through a window;
- moving/dragging a weight (150 pounds); changing direction on the run.

The candidate starts the course at a point, indicated in green on the course map.

The course is outlined as such:

- The candidate runs one and $\frac{3}{4}$ laps around the perimeter of the course
- The first obstacle encountered in the interior consists of two low hurdles, one and a half feet high and four feet long, placed 13 feet apart.
- After clearing the hurdles, stairs (five steps up to a 32-inch wide landing, 45 inches above the floor, and five steps down) must be negotiated twice (note that each step has a 7.5 inch rise and tread that is 11 inches wide).
- Once the stair event is completed another low hurdle must be cleared; the trainee must then successfully negotiate a low crawl under an obstacle set at 2 $\frac{1}{2}$ feet above the floor.
- Make a turn and clear a ditch simulation that is six feet in width.
- After another turn, a chain-link fence (four feet in height) must be climbed.
- Two additional turns made, and a four-foot high window (opening is 3' wide x 4.5' high) must be successfully entered.
- The candidate must then drag a 150-pound dead weight a distance of 20 feet.
- After the weight drag, the candidate exits the course, completes one final lap around the perimeter and finishes at the point indicated in red on the course map



STATESBORO POLICE DEPARTMENT

Ph 912-764-9911

25 West Grady Street, Statesboro, Georgia 30458

Fx 912-489-5050

Time Penalty Methods

There are two (2) time penalty methods employed throughout the conduct of the PAT. These are described and contrasted below.

1. At all obstacles (stair climb, chain link fence, window/solid wall), with the exception of the low crawl and ditch jump, each participant is allowed a maximum of three (3) attempts to negotiate each respective obstacle – failing the third, the participant is instructed to walk around the obstacle and continue on the course. Most participants are capable of negotiating each obstacle on the first attempt. If, however, additional attempts are necessary, they are attempted while the clock is running and results, therefore, in a “self-imposed” time penalty.

2. The time penalty for failure to negotiate successfully the low crawl and ditch jump (six feet in length) is an added two (2) second penalty for each failure. These are “staff imposed” penalties. These penalties are added to the cumulative score (time) of a given individual upon completion of the course.

Note: included in item #2 is a two (2) second penalty for failure to negotiate (knocking over) a low hurdle.

